



# **DIN-A-MITE<sup>®</sup> Style C**

## **Solid-State Power Controller**

### **User's Manual**



## **DIN-A-MITE Solid-State Power Controller**

Please consult this user's manual when you place your new DIN-A-MITE into service. It contains all the necessary information to mount and wire the product into the application. This manual also contains all user-pertinent specifications and semiconductor fusing recommendations. Refer to national and local electrical code safety guidelines whenever you install electrical equipment.

The Watlow DIN-A-MITE power controller includes single-phase, 3-phase, 2-leg, and 3-phase, 3-leg, 120 to 600V~ (ac) operation. Current switching capabilities range from 30 to

80A, depending on the model ordered. See the output rating curves.

Zero-cross variable time base or  $V_{\approx}$  (ac/dc) input contactor versions are available. Shorted SCR (silicon controlled rectifier) and open-heater protection is available on some zero-cross models. Phase angle and phase angle with current limit is also available on single-phase models. The model number indicates the power controller's configuration.

The DIN-A-MITE power controller is designed and manufactured by Watlow in Winona, Minnesota.



1241 Bundy Boulevard, Winona, Minnesota USA 55987  
Phone: +1 (507) 454-5300, Fax: +1 (507) 452-4507 <http://www.watlow.com>

0600-0025-0009 Rev J



Made in the U.S.A.

June 2005

\$5.00

## General Specifications

### Operator Interface

- Command signal input and indication light
- Alarm output and indication light
- Current limit indication LED

### Amperage Rating

See the output rating curve chart on page 5 for all the natural convection, fan-cooled, and through-wall mount models.

Ratings are into a resistive heater load

- Maximum surge current for 16.6 milliseconds, 1,350 A peak
- Maximum  $I^2t$  for fusing is 9100 A<sup>2</sup>s
- Latching current: 500mA minimum
- Holding current: 200mA minimum
- Fan current: 0.14 A for 24V~ (dc); 0.12 A for 120V~ (ac); 0.06A for 240V~ (ac)
- Off-state leakage 1mA at 25°C (77°F) maximum

### Line Voltage

- 24 to 48V~ (ac) units: 20V~ minimum to 53V~ maximum
- 120 to 240V~ (ac) units: 48V~ minimum to 265V~ maximum
- 277 to 600V~ (ac) units: 85V~ minimum to 660V~ maximum

### Alarms (zero cross models only)

#### Shorted SCR Alarm Option

- Alarm state when the input command signal is off and a 10 A or more load current is detected by the current transformer (two turns required for 5 A or three turns for 2.5 A).

#### Open Heater Alarm Option

- Alarm state when the input command signal is on and the load current detected by the current transformer is less than the alarm set point. Available with Input Control Signal option S only.

#### Alarm Output

- Energizes on alarm, non-latching
- Triac 24 to 240V~ (ac), external supply with a current rating of 300 mA @ 25°C (77°F), 200mA @ 50°C (122°F), 100mA @ 80°C (176°F) and a holding current of 200  $\mu$ A with a latching current of 5mA typical.

#### Agency Approvals

- CE with proper filter:  
89/336/EEC Electromagnetic Compatibility Directive  
EN 61326: Industrial Immunity Class A emissions  
Not suitable for Class B environments.

### 73/23/EEC Low Voltage Directive

EN 50178 Safety Requirements  
Installation category III, Pollution degree 2

Phase angle and phase angle with current limit Input Control Signal Types (P and L) are not CE approved.

- UL® 50 Type 4X Enclosure and UL® 1604 File E184390 (Through-wall heatsink mounting only)
-  UL® 508 listed and C-UL®, File E73741

- Shock and vibration tested to IEC 60068-2-32
- Vibration tested to IEC 60068-2-6

### Input Terminals

- Compression: Will accept 0.2 to 1.5 mm<sup>2</sup> (24 to 16 AWG) wire
- Torque to 0.5 Nm (4.4 in-lb) with a 3.5 mm (1/8 in) blade screwdriver
- Wire strip length 5.5 mm (0.22 in)

### Line, Load and Ground Terminals

- Compression: Will accept 2 to 21 mm<sup>2</sup> (14 to 4 AWG) wire
- Torque to 2.7 Nm (24 in-lb) with a 6.4 mm (1/4 in) blade screwdriver, or a Type 1A #2 Pozi driver.
- Retorque after 48 hours to minimize wire cold flow.
- Retorque line and load terminals every 3 to 6 months.
- Wire strip length 11 mm (7/16 in)

### Operating Environment

- See the output rating curve chart on page 5.
- 0 to 90% RH (relative humidity), non-condensing
- Storage temperature: -40 to +85°C (-40 to 185°F)
- Insulation only tested to 3,000 meters

### DIN Rail Mount

- DIN EN 50022, 35 by 7.5 mm
- Minimum clipping distance: 34.8 mm (1.37 in)
- Maximum clipping distance: 35.3 mm (1.39 in)

### Back Panel Mount

- Four mounting holes M4 (No. 8) fastener

### Through-Wall Mount

- See page 8 for through-wall cutout

### NOTE: Mount cooling fins vertically.

### Weight

- 1.0 to 1.9 kg (2.2 to 4.2 lb) depending upon model

Specifications are subject to change without notice.

## Additional Specifications for Contactors and Proportional Controls

### Control Mode, Zero-Cross

- Input Control Signal Type C:  $V_{\sim}$  (dc) input contactor.  
To increase service life, the cycle time should be less than 3 seconds.
- Input Control Signal Type K:  $V_{\sim}$  (ac) input contactor.  
To increase service life, the cycle time should be less than 3 seconds.
- Input Control Signal Type F: 4 to 20mA $\rightleftharpoons$  (dc) proportional variable time base control.

### Input Command Signal

- AC contactor  
24V $\sim$   $\pm 10\%$ , 120V $\sim$   $+10\%/-25\%$ , 240V $\sim$  (ac)  $+10\%/-25\%$  @ 25mA maximum per controlled leg
- Do not use the DIN-A-MITE Vac-input models with a temperature controller that includes an RC snubber circuit across its output. Remove the RC snubber circuit before placing the DIN-A-MITE into service.

- DC Contactor  
4.5 to 32V $\rightleftharpoons$  (dc): maximum current @ 4.5V $\rightleftharpoons$  (dc) is 6mA per leg. Add 2mA per LED used to the total current.
- Loop powered linear current  
4 to 20mA $\rightleftharpoons$  (dc): loop-powered. Input Type F0 option only. (Requires current source with 6.2V $\rightleftharpoons$  (dc) available. No more than three inputs connected in series.)

### Linearity (Input Control Signal Type F)

- Full on point 19.5 to 19.9mA $\rightleftharpoons$  (dc), maximum voltage of 6.2V peak.
- $\pm 5\%$  input to output power accuracy, 0% to 100% of span (4.3 to 19.7mA or 12.3 to 19.7mA).
- Temperature stability is less than 0.15%/°C change.

## Additional Specifications: Phase Angle; Phase Angle Current Limit; & Single Cycle VTB

### Operation

- Burst firing (zero-cross) control, single-cycle variable time base, Type S single-phase and 3-phase. Unit is not on for more than one full cycle under 50% power and not off for more than one full cycle above 50% power.
- Phase angle control, single-phase only

### Input Command Signal

- 0 to 20mA, 4 to 20mA, 12 to 20mA,  $\rightleftharpoons$  (dc), 0 to 5V $\rightleftharpoons$ , 1 to 5V $\rightleftharpoons$ , and 0 to 10V $\rightleftharpoons$
- Input impedance 250  $\Omega$  for 4 to 20mA, 5k  $\Omega$  for linear voltage input

### Output Voltage

- 100 to 120V $\sim$  (ac), 200 to 208V $\sim$ , 230 to 240V $\sim$ , 277V $\sim$ , 400V $\sim$ , 480V $\sim$ , 600V $\sim$ ,  $-15\%/+10\%$ , 50 or 60 Hz independent  $\pm 5\%$  (Input Control Signal Type L, P and S)

### Phase Angle Accuracy

- Output on time is directly proportional to the command signal. Output on time is accurate to within 5% of the command signal input at 25 degrees C ambient. See chart below for command signal input to output power transfer function. Temperature stability at ambient temperature is less than 0.25%/degrees C.

### Single Cycle VTB Accuracy

- Output power is directly proportional to the command signal. Output power is accurate to within 5% of the command signal input at 25 degrees C ambient. Temperature stability is less than 0.25%/degrees C ambient temperature change.

### Soft Start

#### (Phase Angle Input Control Signal Type P and L)

Typically:

- 5 seconds soft start on power up
- Soft start on thermostat overtemperature
- Soft start on 1/2 cycle drop out detection
- 1 second soft switching on set point change

### Options

- Manual Control Kit (1k potentiometer) 08-5362
- Alarm option is **not** available on phase angle type P or type L.

### Resolution

- Better than 0.1% of input span with respect to output change.

### Phase Angle Command Signal Input to Output Power

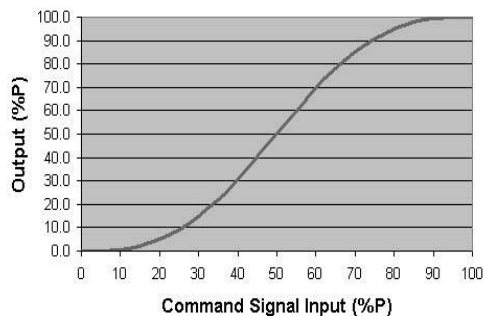

## DIN-A-MITE C Ordering Information

To order, complete the code number on the right with the information below:

Style C solid-state power controller

**DC** - - - - -

### Phase

- 1 = single-phase, 1 controlled leg
- 2 = 3-phase, 2 controlled legs
- 3 = 3-phase, 3 controlled legs (use with four-wire wye)
- 8 = 2 independent zones (input control C, K)
- 9 = 3 independent zones (input control C, K)

### Cooling and Current Rating Per Leg

- 0 = Natural convection standard DIN rail or panel heatsink
- 1 = Fan-cooled 120V~ (ac) standard DIN rail or panel heatsink
- 2 = Fan-cooled 240V~ (ac) standard DIN rail or panel heatsink
- 3 = Fan-cooled 24V= (dc) fan standard DIN rail or panel heatsink
- T = Natural convection through-wall or cabinet heatsink (UL 50)

### Line and Load Voltage

- 02 = 24 to 48V~ (ac) (Input Control Signal C, F, or K only)
- 12 = 100 to 120V~ (ac) (Input Control Signal L, P or S only)
- 20 = 200 to 208V~ (ac) (Input Control Signal L, P or S only)
- 24 = 120 to 240V~ (ac) (Input Control Signal C, F or K only);  
230 to 240V~ (ac) (Input Control Signal L, P or S only)
- 27 = 277V~ (ac) (Input Control Signal L, P or S only)
- 40 = 400V~ (ac) (Input Control Signal L, P or S only)
- 48 = 480V~ (ac) (Input Control Signal L, P or S only)
- 60 = 277 to 600V~ (ac) (Input Control Signal C, F or K only);  
600V~ (ac) (Input Control Signal L, P or S only)

### Input Control Signal

- C0 = 4.5 to 32V= (dc) contactor
  - K1 = 22 to 26V~ contactor
  - K2 = 100 to 120V~ contactor
  - K3 = 200 to 240V~ contactor
  - F0 = Proportional 4 to 20 mA (loop powered)
  - L(0 to 5) = Phase angle with current limiting (DC1 only, Alarm 0 only,  
includes one current transformer - Single phase only) ①
  - P(0 to 5) = Phase angle (DC1 only, Alarm 0 only - Single phase only) ①
  - S(0 to 5) = Single-cycle variable time base
- (Select one of the following input options for L, P, S, (0 to 5))
- 0 = 4 to 20mA
  - 1 = 12 to 20mA (for Input Control Signal option S only)
  - 2 = 0 to 20mA
  - 3 = 0 to 5V= (dc) proportional
  - 4 = 1 to 5V= (dc) proportional
  - 5 = 0 to 10V= (dc) proportional

### Alarm

- 0 = No alarm
- S = Shorted-SCR alarm (not available on Phase options 8 & 9 or Control options L & P)
- H = Open-heater and shorted-SCR alarm (for Input Control Signal option S only)

### User Manual Language

- 0 = English
- 1 = German
- 2 = Spanish
- 3 = French

### Custom Part Numbers

- 00 = Standard part
- 1X = 1-second soft start (control option P, L)
- XX = Any letter or number, custom options, labeling, etc.

① Not CE compliant for conducted or radiated emissions

### Recommended semiconductor fuse for applications through 600V~ (ac):

Fuse part number				Fuse Holder part number		
Fuse Rating	Wattlow	Bussmann	Ferraz	Fuse Rating	Wattlow	Ferraz
40A	17-8040	FWP-40A14F	A093909	40A	17-5114	US141i
50A	17-8050	FWP-50A14F	B093910	50A	17-5114	US141i
63A	17-8063	FWP-63A22F	T094823	63A	17-5122	US221i
80A	17-8080	FWP-80A22F	A094829	80A	17-5122	US221i
100A	17-8100	FWP-100A22F	Y094827	100A	17-5122	US221i

### Current Rating Table

Model (first 4 digits of part number)	Current at 50°C (122°F)
DC10	55 A
DC1T	62 A
DC11, DC12, DC13	75 A
DC20, DC80	40 A
DC2T, DC8T	46 A
DC21, DC22, DC23	65 A
DC81, DC82, DC83	
DC30, DC90	30 A
DC3T, DC9T	35 A
DC31, DC32, DC33	55 A
DC91, DC92, DC93	

## Output Rating Curves

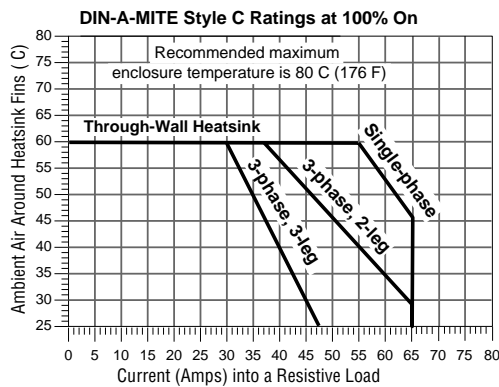
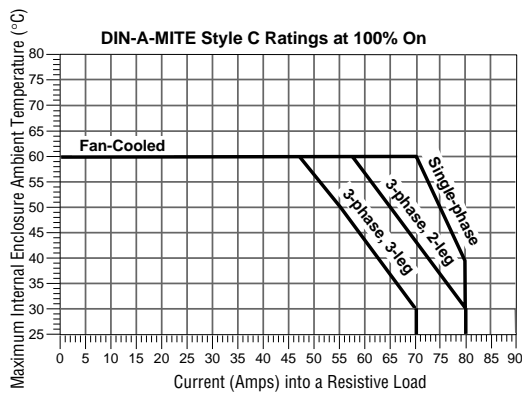
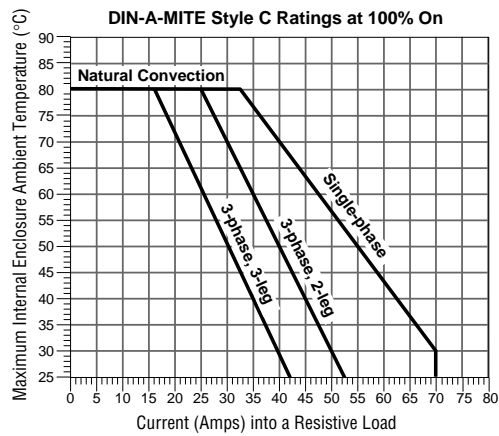

## Extended Heater And SCR Life With Variable Time Base

**Models: DC \_\_ - [02, 24, 60] F0 - \_ \_ \_ \_**  
 20% Power, 3 AC line cycles on, 12 cycles off

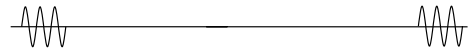

**50% Power, 3 AC line cycles on, 3 cycles off**



With variable time base control, the power controller automatically adjusts the time base and output power with respect to process input. Accelerated life testing verified that the variable time base control significantly reduces expansion and contraction of the heater element. This extends heater and SCR life while improving the process temperature control. You save money on heaters, down time and maintenance.

## Single-Cycle Variable Time Base

**Models: DC \_ \_ - S \_ - \_ \_ \_ \_**  
 25% Power, 1 AC line cycle on, 3 cycles off

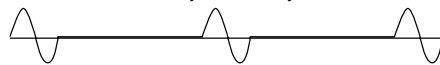

**50% Power, 1 AC line cycle on, 1 cycle off**

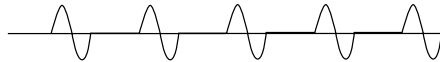

With single-cycle variable time base (VTBS) control, at 50% power, power is on one cycle, and off one cycle. At 25%, it is on for one cycle and off for three. Under 50%, the unit is not on for more than one consecutive cycle. Over 50%, the unit is not off for more than one consecutive cycle. This model will work with a linear voltage input, a 4 to 20mA input or a potentiometer input.

## Phase Angle

**Models: DC1 \_ - \_ \_ [L, P] - 0 \_ \_ \_**

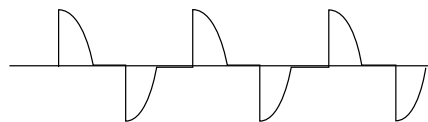

Phase angle control (control Type P) is infinitely variable inside the sine wave. This provides a variable voltage and/or current output. This option includes soft start and line voltage compensation. This model will work with a linear voltage input, a linear current source input or a potentiometer input. This is single-phase only. Alarms not available on phase angle models.

## Mount

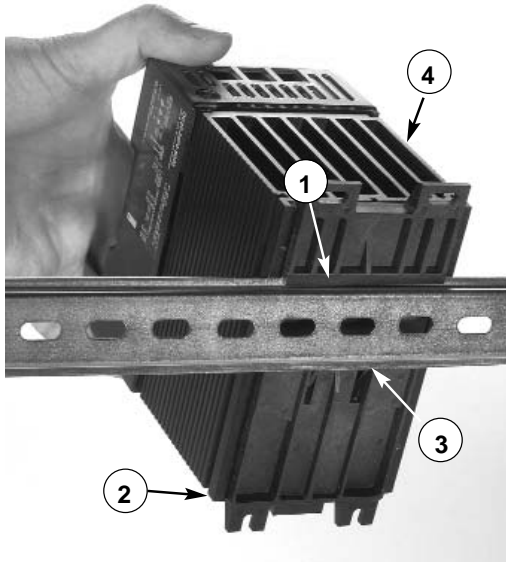

1. Push the unit in and down to catch the rail hook on top of the rail.
2. Rotate the bottom of the unit in toward the rail.
3. The rail clasp will audibly “snap” into place. If the DIN-A-MITE does not snap into place, check to see if the rail is bent.
4. Mount the cooling fins vertically.

## Dismount

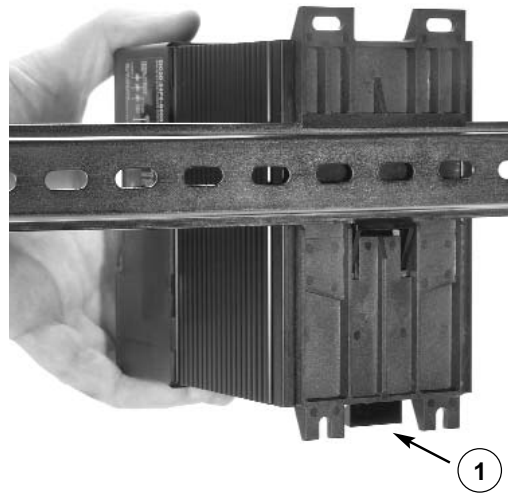

1. Press down on the release tab while rotating the unit up and away from the rail.



**WARNING:**  
Only authorized personnel should be allowed to install and perform preventive and corrective maintenance on this unit. Failure to follow this guideline could result in damage to equipment, and personal injury or death.



**WARNING:**  
Hot surface, do not touch the heat sink. Failure to follow this guideline could result in personal injury.



Mount the cooling fins vertically. ↑

## Unit Dimensions - Fan-Cooled

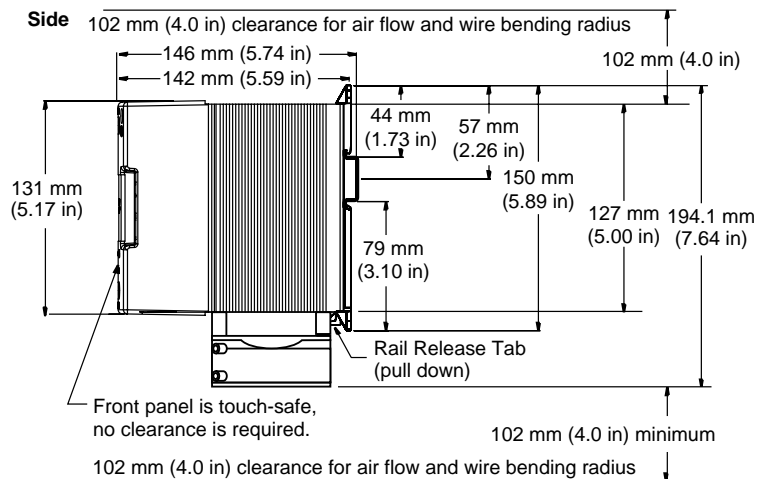

## Unit Dimensions - Rail-Mounted



**WARNING:**  
Only authorized and qualified personnel should be allowed to install and perform preventive and corrective maintenance on this unit. Failure to follow this guideline could result in damage to equipment, and personal injury or death.



**WARNING:**  
Hot surface, do not touch the heat sink. Failure to follow this guideline could result in personal injury.



**Mount the cooling fins vertically.**

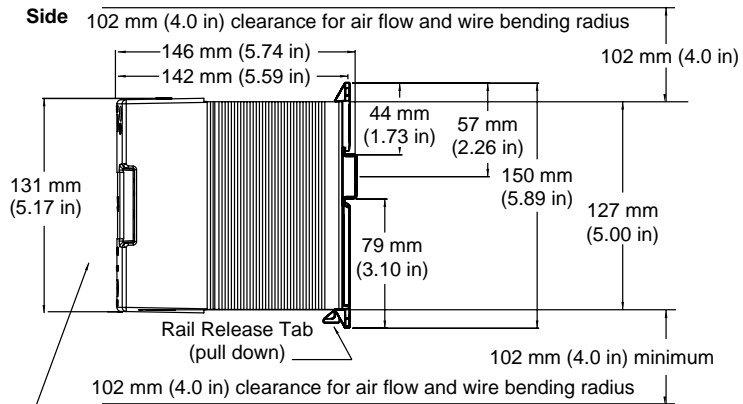
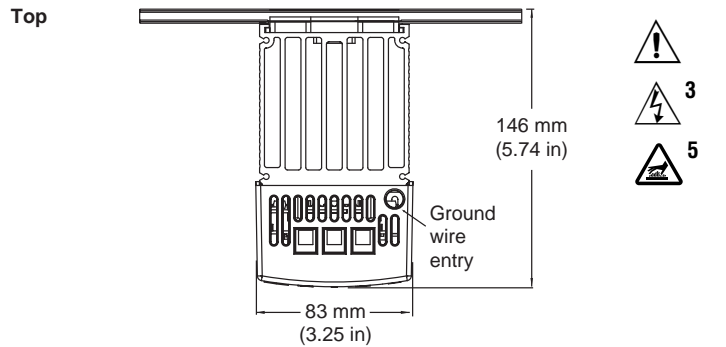

Front panel is touch-safe, no clearance is required.

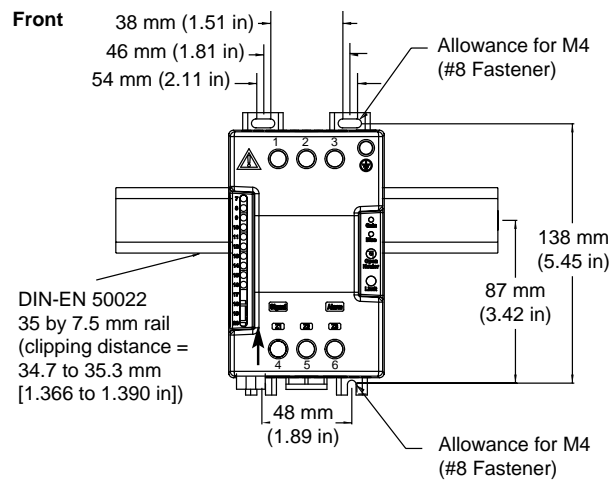

## Mounting

## Unit Dimensions - Through-Wall (Cabinet Panel)

### Mounting procedure for UL® 50 Type 4X Enclosure and UL® 1604 Through-wall mount models

Materials included:

- (1) Silicone gasket
- (8) M5 screws and lockwashers
- (1) DIN-A-MITE C through-wall

1. Drill and cut the panel as shown in the dimensioned drawing at right.
2. Remove the mounting screws from the heatsink.
3. Peel off the protective film from the silicone gasket. Stick the gasket to the heatsink so the gasket holes line up with the screw holes in the heatsink.
4. Mount the heatsink vertically. Torque to 2.26 to 2.82 Nm (20 to 25 in-lb).

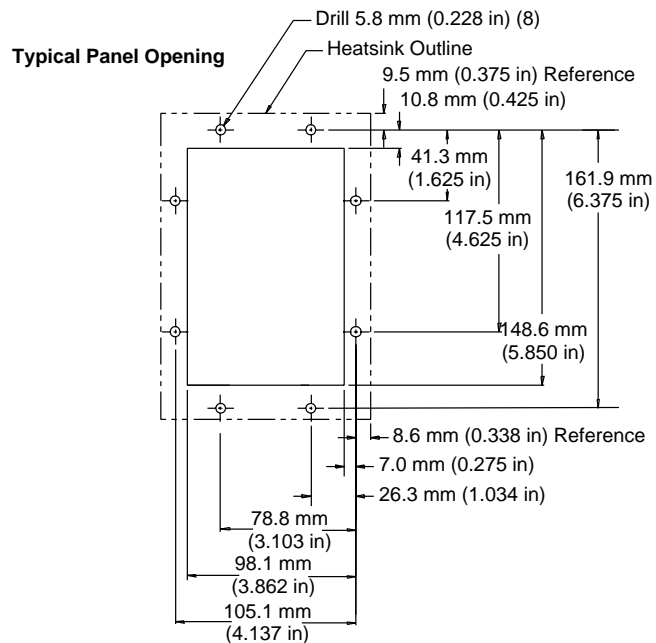
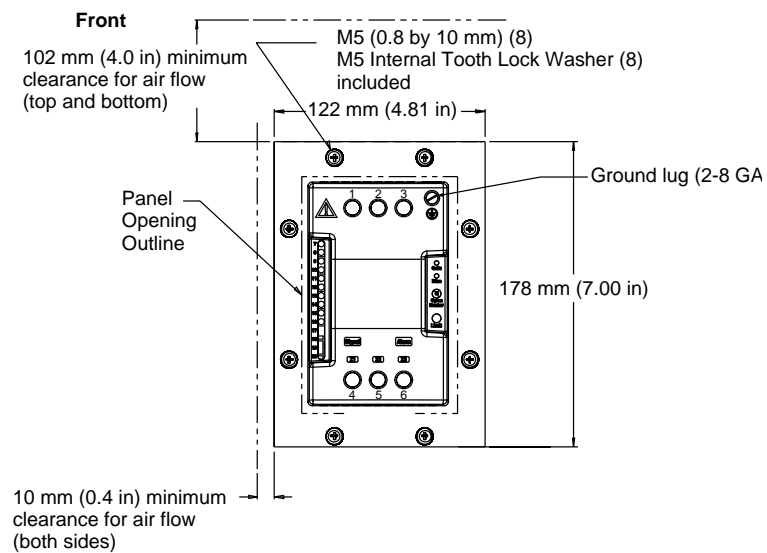
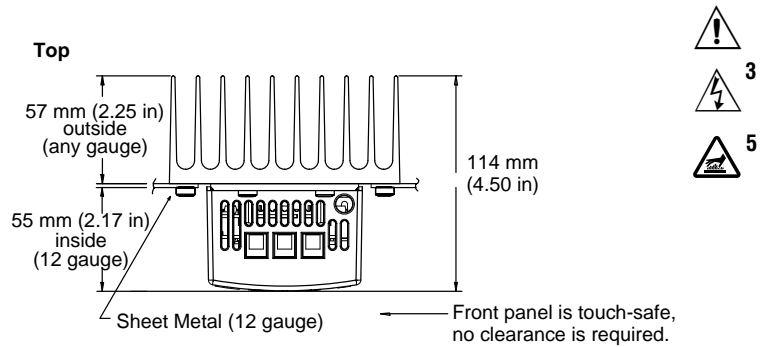





**WARNING:**  
Use National Electric (NEC) or other country-specific standard wiring practices to install and operate the DIN-A-MITE. Failure to do so may result in damage to equipment and property, and/or injury or loss of life.



**WARNING:**  
Only authorized and qualified personnel should be allowed to install and perform preventive and corrective maintenance on this unit. Failure to follow this guideline could result in damage to equipment, and personal injury or death.



**WARNING:**  
Do not use the DIN-A-MITE Vac-input models with a temperature controller that includes an RC snubber circuit across its output. Remove the RC snubber circuit before placing the DIN-A-MITE into service.

**NOTE:**  
Alarm options not available with multizone input option.

## Input Wiring

(For models DC [1, 2, 3] \_ \_ \_ [C, F, K] \_ \_ \_ \_ \_)

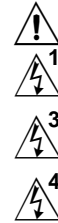
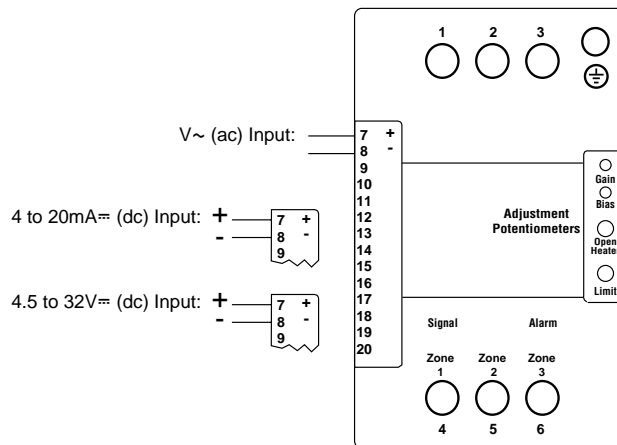

## Multizone Input Wiring

(For models DC [8, 9] \_ \_ \_ [C, K] - 0 \_ \_ \_ \_)

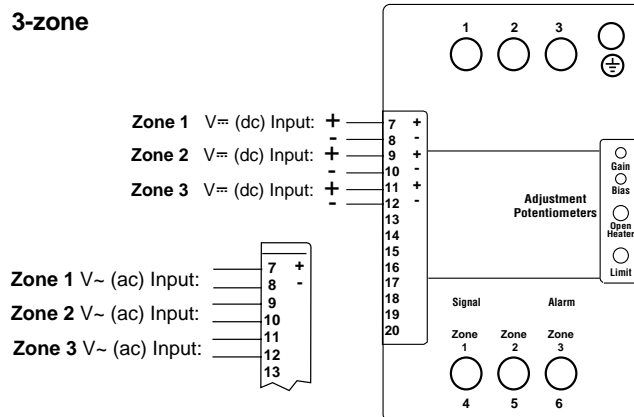
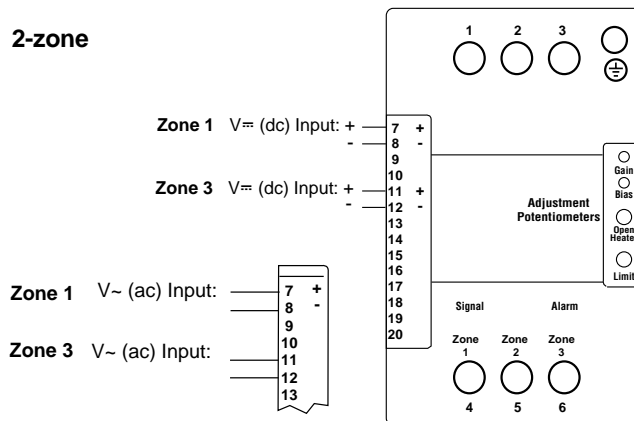

## Input Wiring



**NOTE:**  
The potentiometer is customer-supplied. For the potentiometer only, order Watlow part number 08-5362.

(For models DC [1, 2, 3] \_ - \_ \_ [L, P, S] \_ - \_ \_ \_ \_)

### 4 to 20mA and Linear Voltage Input

#### 1kΩ Potentiometer Input

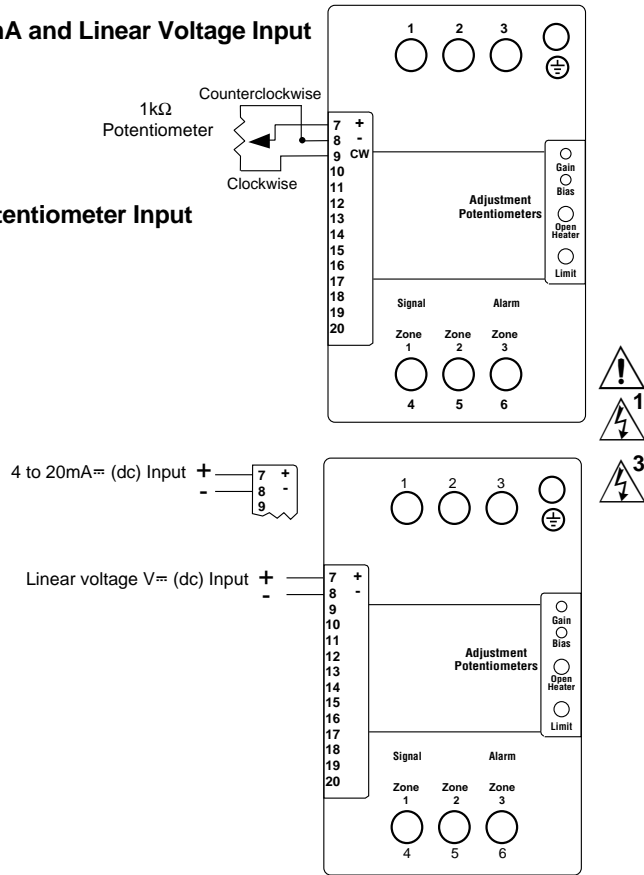

## Auto and Manual Input Application

(For models DC [1, 2, 3] \_ - \_ \_ [L, P, S] [3, 4] - \_ \_ \_ \_)

When you use the 4 to 20 mA<sup>ac</sup> (dc) temperature controller output and the DIN-A-MITE control input 1 to 5V<sup>ac</sup> (dc).

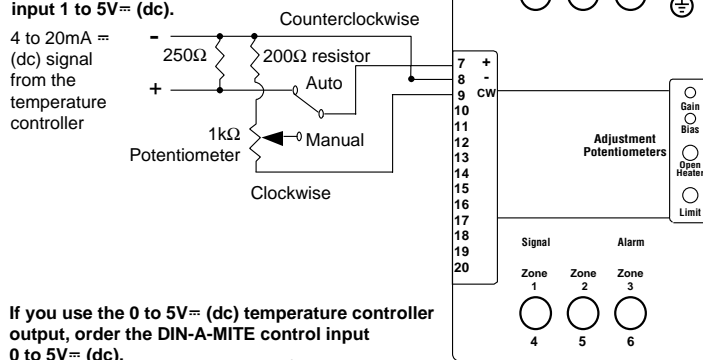

**NOTE:**  
The potentiometer and resistors are customer-supplied. For the potentiometer control assembly only, order Watlow part number 08-5362.

If you use the 0 to 5V<sup>ac</sup> (dc) temperature controller output, order the DIN-A-MITE control input 0 to 5V<sup>ac</sup> (dc).

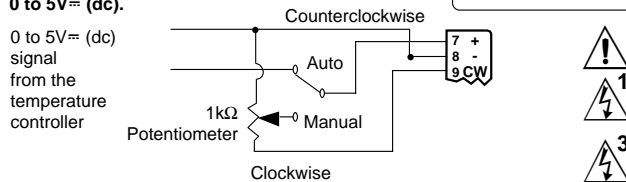



**WARNING:**  
Use National Electric (NEC) or other country-specific standard wiring practices to install and operate the DIN-A-MITE. Failure to do so may result in damage to equipment and property, and/or injury or loss of life.



**WARNING:** Wiring examples show L2 in phase-to-phase, 200V~ (ac) and above configuration. In phase-to-neutral, 100V~ (ac) and above applications, L2 is neutral and must not be fused or switched. Failure to follow this guideline could result in personal injury or death.



**WARNING:**  
Only authorized and qualified personnel should be allowed to install and perform preventive and corrective maintenance on this unit. Failure to follow this guideline could result in damage to equipment, and personal injury or death.

**NOTE:**  
The alarm options are not available with phase angle units.

## Input Wiring Phase Angle with Current Limit

(Model DC1 \_ - \_ \_ L [0, 1, 2, 3, 4, 5] - \_ \_ \_ \_ )

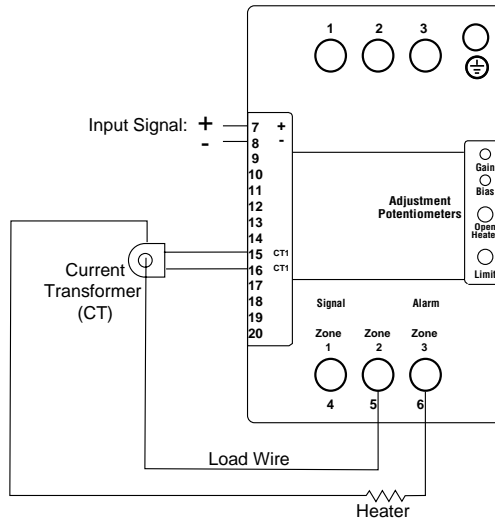

The Zone 3 indicator light serves as the current-limit indicator in phase-angle, current-limit models.

## Current Limit Adjustment Procedure

The DC1 \_ - \_ \_ L \_ - 0 \_ \_ \_ model is a phase angle-controller that can limit the maximum current to the load. A potentiometer on the DIN-A-MITE adjusts the current limit setting. Use the following steps to adjust the current limit on initial setup. The purpose of the procedure is to bring the power to the load slowly so that the desired maximum current to the load is not exceeded before the current limit is adjusted.

**NOTE:** The DIN-A-MITE is shipped factory-calibrated with the potentiometer adjusted fully clockwise (no current limiting). Adjust the potentiometer clockwise to increase the current; counterclockwise to decrease the current.

**NOTE:** A short overcurrent through the load may occur, as the circuitry detects the high current, if the input signal from the temperature controller is abruptly increased.

1. Attach a clamp-on ammeter to the load line.
2. Adjust the current limit potentiometer fully counterclockwise (for minimum current flow).
3. Turn the temperature controller on and adjust the input signal to the DIN-A-MITE for zero percent power.
4. Turn on the power to the DIN-A-MITE.
5. Gradually increase the input signal.
6. Adjust the current limit potentiometer clockwise until the current to the load is measurable. The current limit indicator (Zone 3) light should turn on until the output is allowed to go full on, with no limit. At that point, the indicator light will turn off.
7. Gradually increase the input signal to 100% power, then adjust the current limit potentiometer to obtain the desired maximum current to the load.

## Single-phase Alarm

### Non-latching Alarm Option DC \_ \_ - \_ - [H, S] \_ \_ \_

**NOTE:** If you plan to wire multiple DIN-A-MITE alarm outputs, you need to include an intermediate relay for each DIN-A-MITE used.

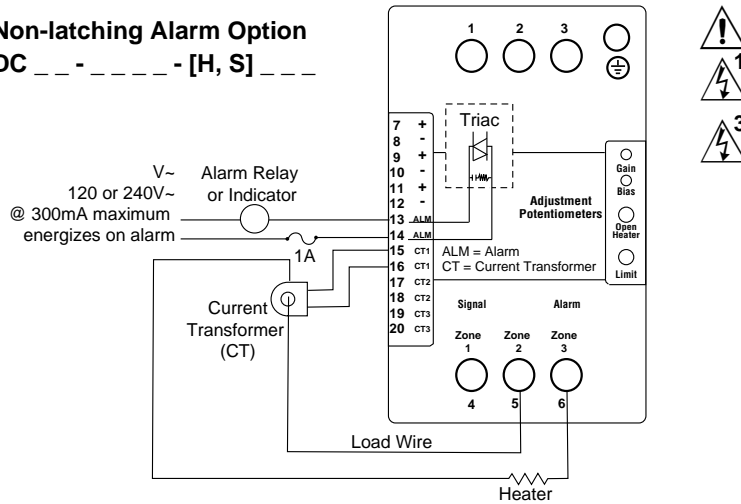

The Watlow DIN-A-MITE alarm option provides a common alarm output for open-heater or shorted SCR conditions. **This is a non-latching alarm.**

- A shorted SCR alarm is detected when there is no command signal and a load current is detected. The alarm output is then energized.
- An open-heater or partial open-heater state is detected when a command signal is present and a reduced or no output current is detected. The alarm output is then energized.

Load Current	Passes of Load Wire Through the Current Transformer
5 to 9A	2
10 to 65A	1

### Setup Procedure for Open-Heater Alarm (For Input Control Signal type S option only)

1. With the temperature control wired to the DIN-A-MITE SCR power control, set the temperature control output to “full on” (20mA for 4 to 20mA output, or 5V for 0 to 5V output).
2. Adjust the open heater alarm adjustment potentiometer until the alarm indicator light on the front panel is full on, with no intermittent cycling.
3. Slowly adjust the potentiometer until the open heater indicator light just turns full off, with no intermittent cycling.

If you are getting false alarms, the adjustment is probably set too sensitive and should be re-adjusted towards the off condition of the open-heater indicator light.

No setup procedure required for shorted SCR alarm.

## 3-phase, 2-leg Open Heater Alarm

(Model DC2 \_ \_ \_ S \_ H \_ \_ \_)

**NOTE:** Load wires must pass through each current transformer in the same direction.

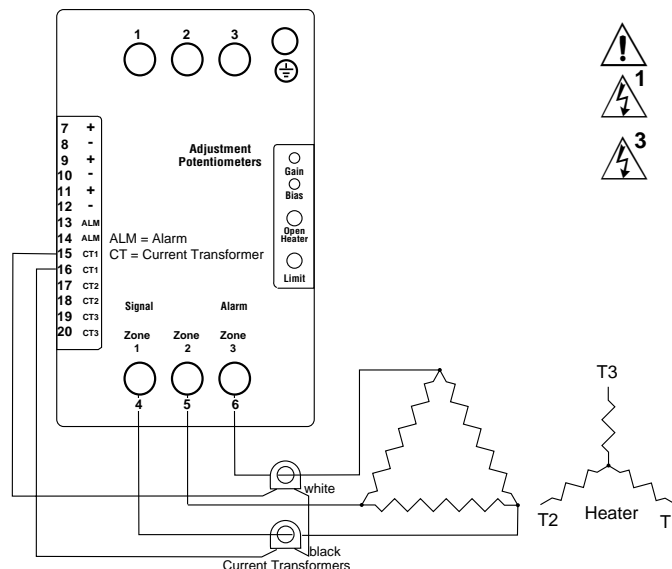



**NOTE:**  
Adjust the potentiometer clockwise to increase the current; counterclockwise to decrease the current.



**WARNING:**  
Use National Electric (NEC) or other country-specific standard wiring practices to install and operate the DIN-A-MITE. Failure to do so may result in damage to equipment and property, and/or injury or loss of life.



**WARNING:**  
Only authorized and qualified personnel should be allowed to install and perform preventive and corrective maintenance on this unit. Failure to follow this guideline could result in damage to equipment, and personal injury or death.

**NOTE:**  
The shorted SCR alarm option is not available with phase angle units.

**Torque Guidelines**

- Properly torque line and load terminals to 2.7 Nm (24 in-lb).
- Retorque after 48 hours to minimize wire cold flow.
- Retorque line and load terminals every 3 to 6 months.

**3-phase, 2-leg Shorted SCR Alarm**

(Model DC2 \_ - \_ \_ [C, F, K, S] \_ - S \_ \_ \_ )

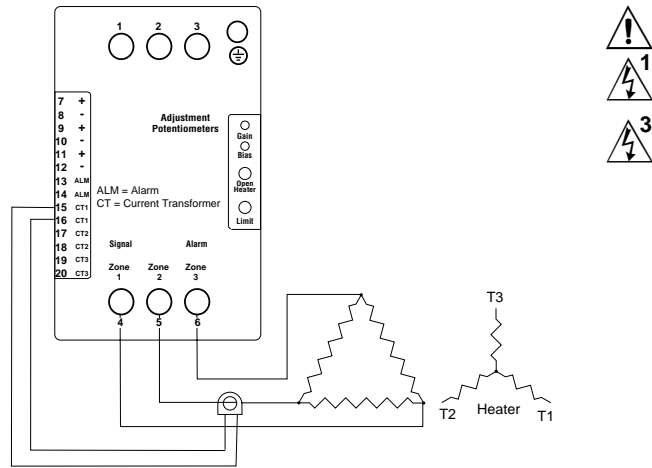

**3-phase, 3-leg Alarm, Shorted SCR and Open Heater Alarm**

(Model DC3 \_ - \_ \_ \_ - [S, H] \_ \_ \_ )

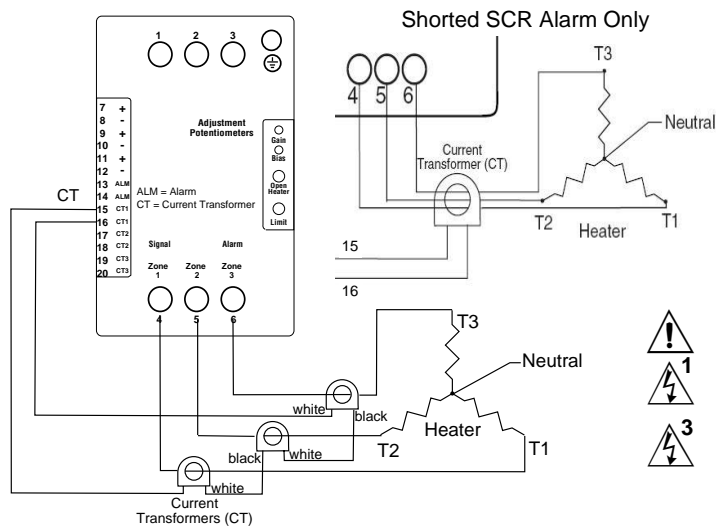

**Fan-Cooled**

Fan power required  
24V= (dc)  
120V~ (ac)  
240V~ (ac)  
(customer supplied)

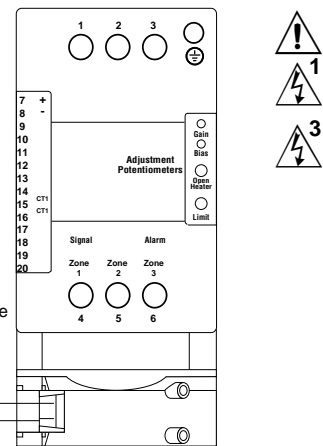
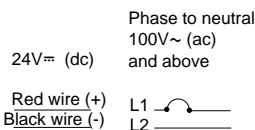



1



**WARNING:**  
Use National Electric (NEC) or other country-specific standard wiring practices to install and operate the DIN-A-MITE. Failure to do so may result in damage to equipment and property, and/or injury or loss of life.

2



**WARNING:**  
Wiring examples show L2 in phase-to-phase, 200V~ (ac) and above configuration. In phase-to-neutral, 100V~ (ac) and above applications, L2 is neutral and must not be fused or switched. Failure to follow this guideline could result in personal injury or death.

3



**WARNING:**  
Only authorized and qualified personnel should be allowed to install and perform preventive and corrective maintenance on this unit. Failure to follow this guideline could result in damage to equipment, and personal injury or death.

#### Torque Guidelines

- Properly torque line and load terminals to 2.7 Nm (24 in-lb).
- Retorque after 48 hours to minimize wire cold flow.
- Retorque line and load terminals every 3 to 6 months.

### Single-phase Output

(Model DC1 - - - - - )

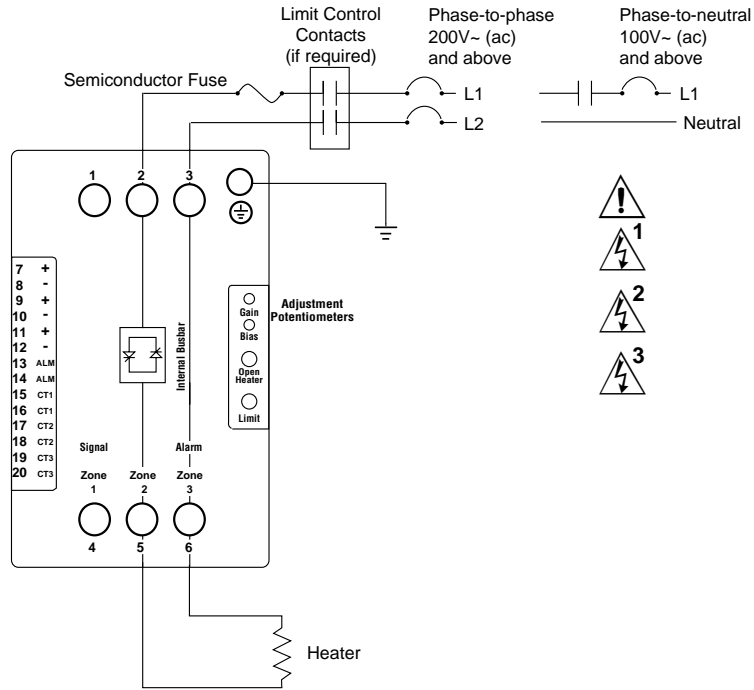

### 3-phase, 2-leg Output

(Model DC2 - - - - - )

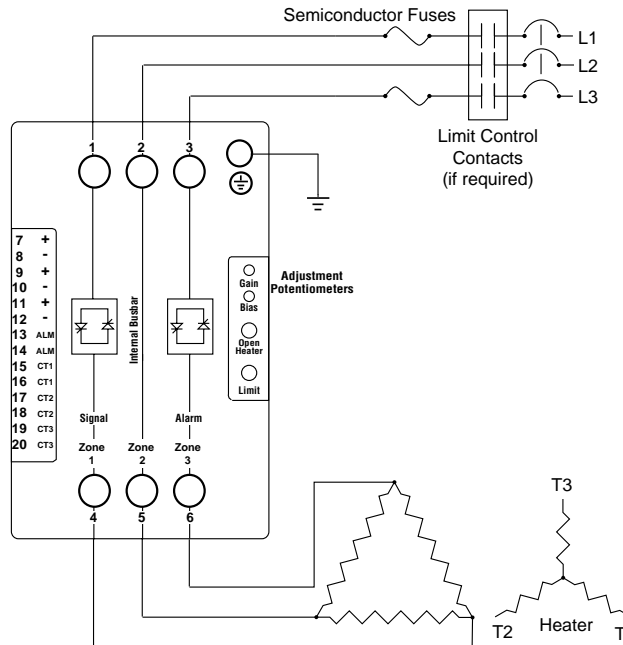

### 3-phase, 3-leg Output, Four Wire Wye

(Model DC3 \_ - - - - - )

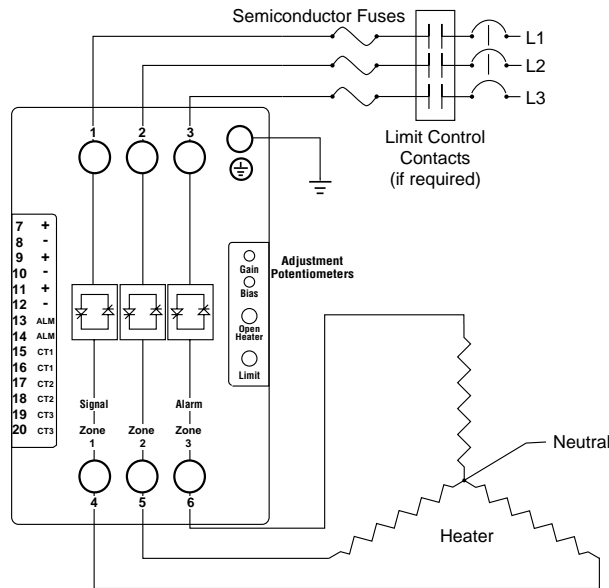

### Multizone Output Wiring

(For models DC [8, 9] \_ - - - [C, K] \_ - 0 \_ - - )

2-zone

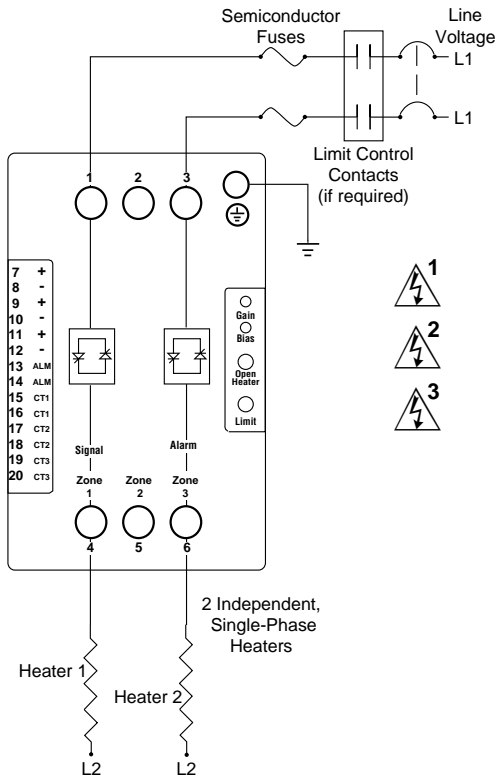

3-zone

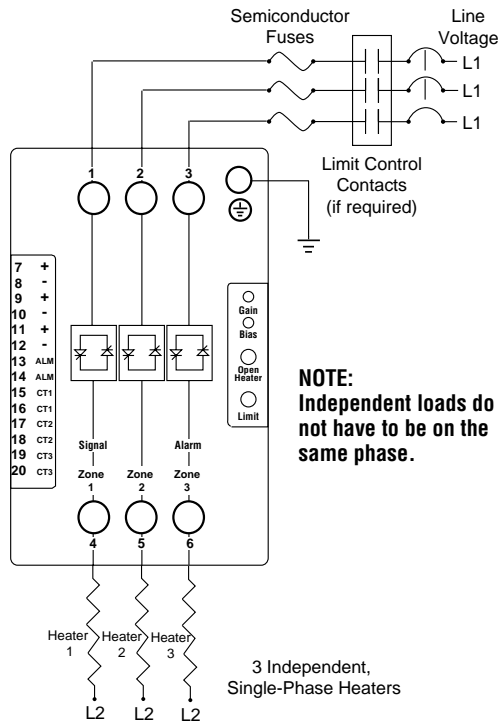

**NOTE:**  
Independent loads do not have to be on the same phase.

## System Wiring Example



**WARNING:**  
Use National Electric (NEC) or other country-specific standard wiring practices to install and operate the DIN-A-MITE. Failure to do so may result in damage to equipment and property, and/or injury or loss of life.



**WARNING:**  
Wiring examples show L2 in phase-to-phase, 200 V~ (ac) and above configuration. In phase-to-neutral, 100 V~ (ac) and above applications, L2 is neutral and must not be fused or switched. Failure to follow this guideline could result in personal injury or death.



**WARNING:**  
Only authorized and qualified personnel should be allowed to install and perform preventive and corrective maintenance on this unit. Failure to follow this guideline could result in damage to equipment, and personal injury or death.

**NOTE:** If you plan to wire multiple DIN-A-MITE alarm outputs, you need to include an intermediate relay for each DIN-A-MITE used.

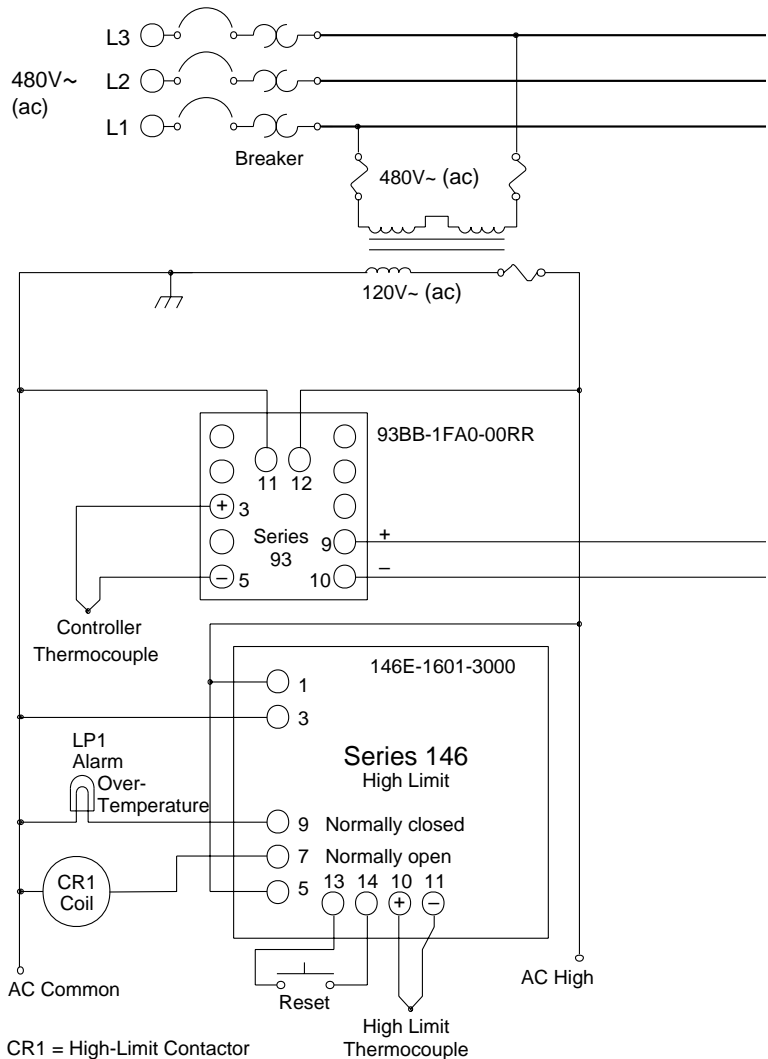

### Alternative Latching Alarm Circuit

If there is a need for a latching alarm in the case of an open heater or shorted SCR, the DIN-A-MITE alarm circuit could be used as shown in the latching alarm example at right. If the DIN-A-MITE triac alarm output energizes, it will energize the RY1 (external alarm relay) mechanical relay coil. Once the RY1 coil is energized it will latch on (via the RY1A normally open contact) until the power to the relay is removed. You could cycle the power via a reset switch. The RY1B contact set can be used for alarm signaling.



**Non-latching Alarm Option**  
(models DC\_\_ - \_\_ S - H \_\_)

**Open Heater and Shorted SCR Alarm**

The shorted SCR detector compares the input command signal and actual load current. If load current is present without an input signal then the shorted SCR alarm will energize a triac (on board the DIN-A-MITE) output.

An open-heater or partial open-heater state is detected when a command signal is present and a reduced or no output current is detected. The alarm output is then energized.

This is a non-latching alarm. This output can be used to drive various indication devices, such as a coil, light, buzzer, etc. See the alternative latching circuit section below.

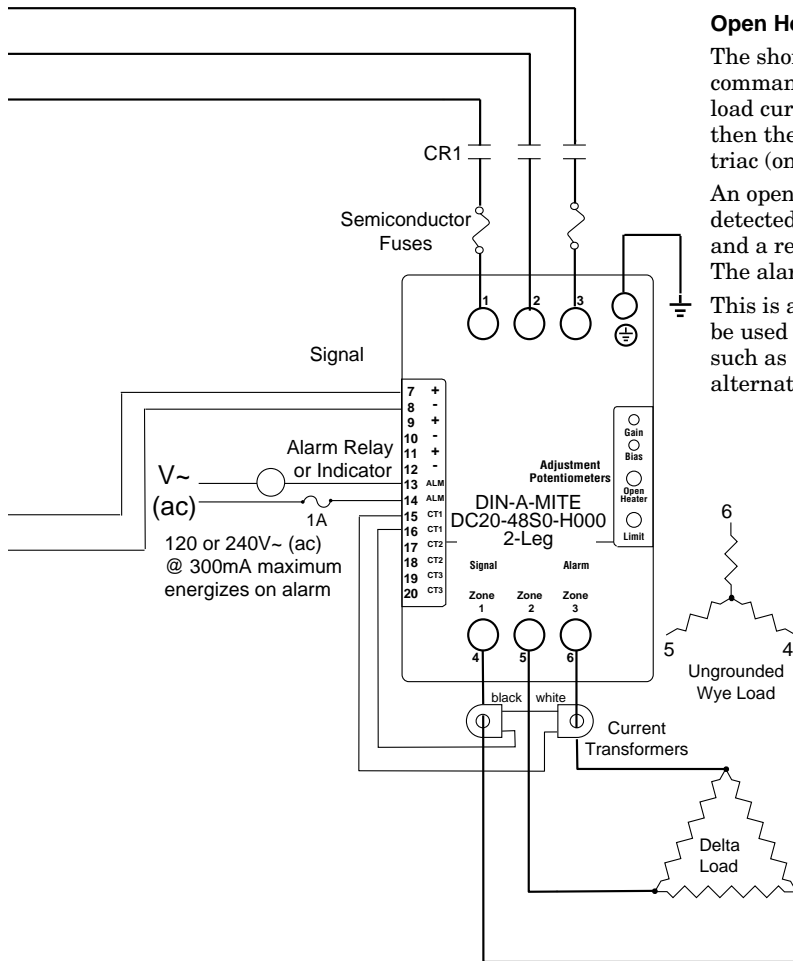

**NOTE: The current transformers must be in the controlled legs on a 2-leg DIN-A-MITE. The load wires must pass through the current transformers in the same direction.**

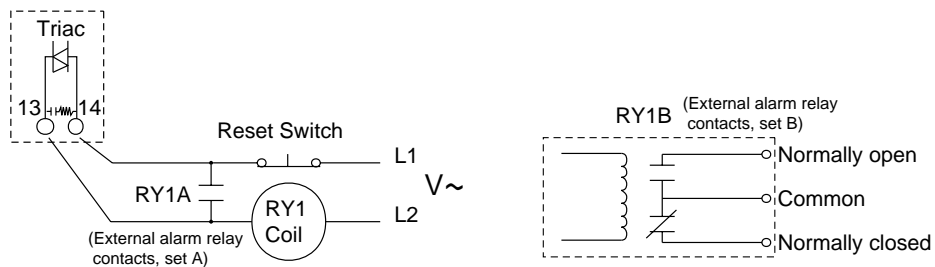

**Latching Alarm Relay Circuit**

# Declaration of Conformity

## DIN-A-MITE® “C” Power Controller

Watlow Winona, Inc.  
1241 Bundy Blvd.  
Winona, MN 55987 USA

---

Declares that the following product: **English**

Designation: **DIN-A-MITE® “C” Power Control**

Model Numbers: DC (1, 2, 3, 8 or 9)(0, 1, 2, 3 or T) – (02, 12, 20, 24, 27, 40, 48 or 60)(C0, C1, C2, K1, K2, K3, F0, F1, S0, S1, S2, S3, S4 or S5) – (0, C, D, H or S)(followed by any 3 numbers or letters.)

Classification: Power Control, Installation Category III, Pollution degree 2

Rated Voltage: 24 to 600V~ (ac)

Rated Frequency: 50 or 60 Hz

Meets the essential requirements of the following European Union Directives by using the relevant standards shown below to indicate compliance.

### **89/336/EEC Electromagnetic Compatibility Directive**

**EN 61326: 1997 With A1:1998 – Electrical equipment for measurement, control and laboratory use – EMC requirements (Industrial Immunity, Group 1 Class A Emissions)**

EN 61000-4-2: 1996 With A1, 1998 – Electrostatic Discharge Immunity

EN 61000-4-3: 1997 – Radiated Field Immunity

EN 61000-4-4: 1995 – Electrical Fast-Transient / Burst Immunity

EN 61000-4-5: 1995 With A1, 1996 – Surge Immunity

EN 61000-4-6: 1996 – Conducted Immunity

EN 61000-4-11: 1994 Voltage Dips, Short Interruptions and Voltage Variations Immunity

EN 61000-3-2: 1995 With A1-3:1999 – Harmonic Current Emissions

EN 61000-3-3: 1995 With A1:1998 – Voltage Fluctuations and Flicker. **See note 3.**

**Note 1: Use of an external filter is required to comply with conducted emissions limits. See page 19 for information and instructions.**

**Note 2: A Line Impedance Stabilization Network (LISN) was used for conducted emissions measurements.**

**Note 3: To comply with flicker requirements, command signal models F0, F1, and S (0-5) may not be used, and cycle time must be set greater than 4 seconds on C0, C1, C2 and K1, K2, K3 models.**

### **73/23/EEC Low-Voltage Directive**

EN 50178: 1997 Electronic equipment for use in power installations.

Raymond D. Feller III Winona, Minnesota, USA  
Name of Authorized Representative Place of Issue

General Manager March 2003  
Title of Authorized Representative Date of Issue



Signature of Authorized Representative

## Required External EMI Filters for DIN-A-MITE with More than 6A Loads

An external EMI filter must be used in conjunction with the DIN-A-MITE for loads in excess of six amperes (6A) at 150 to 250 kHz. Without a filter applied, the DIN-A-MITE does not comply with the conducted emissions standard for loads above 6A at 150 to 250 KHz.

Watlow has verified that two types of filters will suppress electromagnetic interference (EMI) created by the DIN-A-MITE power controller to within the CE requirements.

A tank filter supplied by Crydom or Watlow, installed across the power lines, suppresses EMI on the power lines. See Figures 1 and 2.

See Table 1 for the correct filter.

**⚠ WARNING:**

The tank filters specified may suppress desirable communications carried on power lines in the 150 to 250 kHz region. The filters may suppress carrier current such as that used for infant monitors and medical alert systems. Verify that suppressed carrier current or other desirable communications on power lines creates no hazard to people or property. Failure to observe this warning could result in damage to property, and injury or death for personnel.

**⚡ WARNING:**

All filter installation and wiring must be performed by qualified personnel, and conform to local and national electrical codes. Failure to observe this warning could result in damage to property, and injury or death for personnel.

Description	Crydom Filter	Watlow Filter
Single-phase, 230V~ (ac)	1F25	14-0019
Three-phase, 440V~ (ac)	3F20	14-0020

Table 1— DIN-A-MITE EMI Filters.

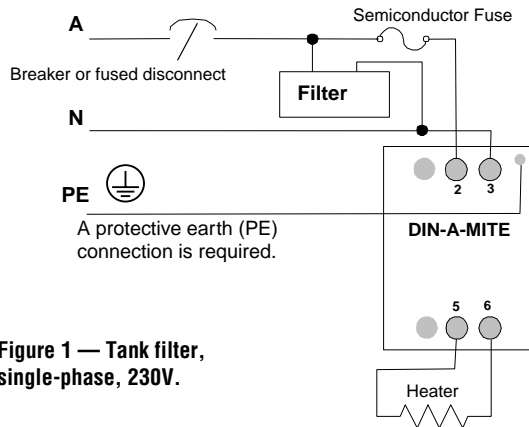

Figure 1 — Tank filter, single-phase, 230V.

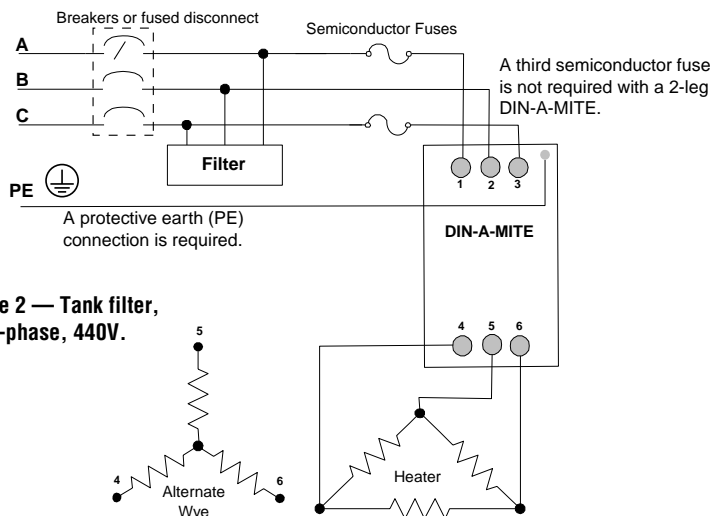

Figure 2 — Tank filter, three-phase, 440V.

## Warranty

The Watlow DIN-A-MITE is warranted to be free of defects in material and workmanship for 36 months after delivery to the first purchaser for use, providing that the units have not been misapplied. Since Watlow has no control over their use, and sometimes misuse, we cannot guarantee against failure. Watlow's obligations hereunder, at Watlow's option, are limited to replacement, repair or refund of purchase price, and parts which upon examination prove to be defective within the warranty period specified. This warranty does not apply to damage resulting from transportation, alteration, misuse, abuse or improper fusing.

## Technical Assistance

If you encounter a problem with your Watlow controller, review your configuration information to verify that your selections are consistent with your application: inputs; outputs; alarms; limits; etc. If the problem persists after checking the configuration of the controller, you can get technical assistance from your local Watlow representative, by e-mailing your questions to [wintechsupport@watlow.com](mailto:wintechsupport@watlow.com) or by dialing +1 (507) 494-5656 between 7 a.m. and 5 p.m., Central Standard Time (CST). Ask for for an Applications Engineer.

Please have the following information available when calling:

- Complete model number
- All wiring and load information
- User's Manual

## Returns

1. Call Watlow Customer Service, (507) 454-5300, for a Return Material Authorization (RMA) number before returning any item for repair. We need the following information:
  - Ship to address
  - Bill to address
  - Contact name
  - Phone number
  - Method of return shipment
  - Your P.O. number
  - Detailed description of the problem
  - Any special instructions
  - Name and phone number of the person returning the product
2. Prior approval and an RMA number, from the Customer Service Department, is required when returning any unused product for credit. Make sure the RMA number is on the outside of the carton, and on all paperwork returned. Ship on a Freight Prepaid basis.
3. After we receive your return, we will examine it and try to verify the reason for the return.
4. In cases of manufacturing defect, we will enter a repair order, replacement order or issue credit for material returned.
5. To return products that are not defective, goods must be in new condition, in the original boxes and they must be returned within 120 days of receipt. A 20 percent restocking charge is applied for all returned stock controls and accessories.
6. If the unit is unrepairable, it will be returned to you with a letter of explanation.
7. Watlow reserves the right to charge for no trouble found (NTF) returns.

The DIN-A-MITE C User's Manual is copyrighted by Watlow, Inc., © September 2004, with all rights reserved.

### Watlow DIN-A-MITE Style C User's Manual

1241 Bundy Boulevard, Winona, Minnesota USA 55987

Phone: +1 (507) 454-5300, Fax: +1 (507) 452-4507 <http://www.watlow.com>