

INSTALLATION GUIDANCE

LP/LT SERIES MULTIVOLTAGE LED BEACONS

LOW VOLTAGE AND EMC DIRECTIVES

This beacon is CE-marked to show compliance with the Low Voltage Directive 2006/95/EC and the EMC Directive 2004/104/EC. To maintain compliance with these directives it is necessary that good installation practice is followed and a qualified electrician should be consulted.

1. This beacon is designed to comply with IP67 when correctly installed. To ensure a weatherproof installation the beacon must be fitted with the foam gasket and mounted on a flat panel or surface forming part of a weatherproof enclosure. The panel or surface should be drilled to accept the wires and M5 studs (see below).

The power supply to the beacon must be fitted with a 500mA fuse.

Access to the power supply wires must be prevented either by fitting a suitable sleeve or by means of a barrier.

2. Connect the red and black wires to a suitable power source (10V - 100Vdc) ensuring that the red wire is connected to the positive terminal.

3. The beacon will flash if the yellow wire is unconnected. Connecting the yellow wire to the negative supply will cause the beacon to operate in a constantly lit mode. For the dual colour beacon, the constantly lit colour will be GREEN, and the flashing colour RED.

LP SERIES

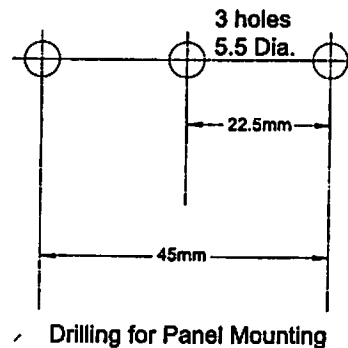
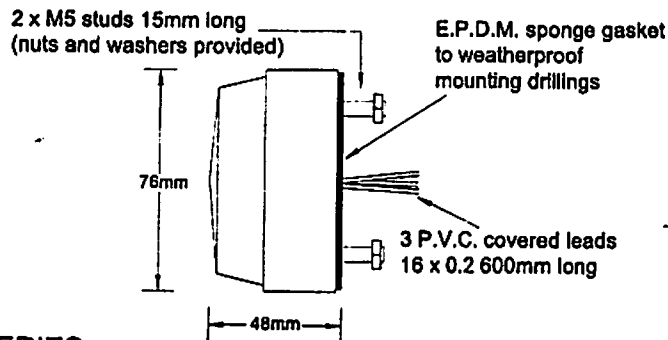

LT SERIES

